

FOFO MEDICAL

Respiratory Product Catalogue

2021—2022

Aerosol Therapy & Accessories
Oxygen Therapy & Accessories
Suction Therapy & Accessories



www.fofomedical.com

FOSHAN HONGFENG CO.,LTD.

NO.4-2, LEQIANG ROAD, LEPING, SANSHUI,
FOSHAN, 528100, GUANGDONG.CHINA
Tel:0086-757-87392028
Mob:0086-13055506651
E-mail: fofomedical.com

Located in:



Foshan Xiamen Danyang

CE FDA ISO13485



TO KNOW MORE
ABOUT US

YouTube

Contents

01 Nebulizers

DC mini Compressor Nebulizer
 Pediatric Nebulizers
 Compact Nebulizers
 Compartment Nebulizers
 Nebulizer Accessories & Motor



02 Suction Machines



03 Oxygen Concentrators



04 Blood Pressure Monitors

05 Medical Air Mattresses

06 Air Compression Therapy Systems



07 Company Instruction

About Us
 Our Group
 Quality Control



BC68006-DC

DC Nebulizer

It is the smallest, lightest, most convenient tabletop nebulizer.
Capable for on the go use via DC car adapter (optional)



Soundless Operation



Portable Size

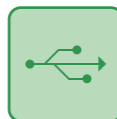

Mini USB 5V, 2A



Family friendly

TECHNICAL FEATURES

- Power Supply: Adapter(5V, 2A)
- Rated Power: <3 W
- MMAD: approx. 3.5 μm
- FPF: approx. 80%
- Nebulizing Rate: 0.20 ml/min
- Nebulizing Head Life: 180 hours
- Max./Min. Liquid Volume: 8 ml/0.5 ml
- Device Net Weight: 157 g
- Device Size: 106 mm x 79 mm x 41 mm

Details:



Mouth-Piece, Nebulizer Cup, Tube, Adult and Pediatric Mask and Air filters, USB cable.

Package content

| Box size (mm) | Carton size(mm) | PCS/CTN | KG/CTN |
|---------------|-----------------|---------|---------|
| 150x123x95 | 495x256x320 | 20 | 7.3/7.8 |

| Product weight | Product size |
|----------------|--------------|
| 0.154KG | 107/79/41 |

BC6403-D

Handle Compressor Nebulizer



Portable size nebulizer compressor nebulizer, easy to use and low noise level.
BC6403-D guarantees effective aerosol therapy by matching high effective Nebulizer Cup.

Package content

| Box size (mm) | Carton size(mm) | PCS/CTN | KG/CTN |
|---------------|-----------------|---------|---------|
| 217x119x258 | 615x222x536 | 10 | 14.1/15 |

| 20GP | 40HQ | Product weight | Product size |
|---------|---------|----------------|--------------|
| 3900PCS | 9300PCS | 1.27KG | 188/107/187 |

BC68005

Compressor Nebulizer



Package content

| Box size (mm) | Carton size(mm) | PCS/CTN | KG/CTN |
|---------------|-----------------|---------|--------|
| 170x115x270 | 595x175x565 | 10 | 14/15 |

| 20GP | 40HQ | Product weight | Product size |
|---------|----------|----------------|--------------|
| 3780PCS | 10910PCS | 1.25KG | 196/160/98 |

BC68006

Compressor Nebulizer



Package content

| Box size (mm) | Carton size(mm) | PCS/CTN | KG/CTN |
|---------------|-----------------|---------|-----------|
| 170x115x235 | 595x175x490 | 10 | 13.5/14.5 |

| 20GP | 40HQ | Product weight | Product size |
|---------|----------|----------------|--------------|
| 4680PCS | 11990PCS | 1.19KG | 140/136/97 |

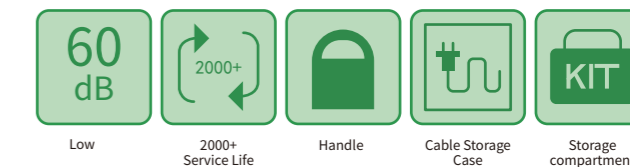

BC68006 and BC68005 are high-end compressor nebulizers, with a low noise level and easy to use. The high performance compressor is suitable for continuous use and has a 2000+ hours non-stop service life.

TECHNICAL FEATURES

- Input: □220V/50HZ □120V/60HZ
- Power Consumption: 65W
- Medication Capacity: 6-8ml
- Particle Size: Respirable Fraction 0.5 to 5μm 0.5μm80%
- MMAD: 3-5μm
- Average Nebulization Rate: Above 0.3ml/min.
- Noise Level: Below 60 dBA
- Compressor Pressure Range: 30-45 Psi
- Operation Pressure Range: 12-14.5 Psi(0.85-1.1 bar)
- Liter Flow Range: 8~ 10 lpm
- Operation Temperature Range: 10°C--40°C (50°F--104°F)
- Operation Humidity Range: 10 to 95% RH

Accessories: Nebulizer cup, adult mask, child mask, inhalation mouth-piece, inhalation tube, air filter.



BC6403

Handle Compressor Nebulizer



Package content

| Box size (mm) | Carton size(mm) | PCS/CTN | KG/CTN |
|---------------|-----------------|---------|---------|
| 295x140x182 | 575x300x385 | 8 | 18/19.2 |

| 20GP | 40HQ | Product weight | Product size |
|---------|---------|----------------|--------------|
| 3440PCS | 8240PCS | 1.34KG | 207/170/102 |

BC68001-B

Compressor Nebulizer



Package content

| Box size (mm) | Carton size(mm) | PCS/CTN | KG/CTN |
|---------------|-----------------|---------|---------|
| 175x175x170 | 540x180x535 | 9 | 13.1/14 |

| 20GP | 40HQ | Product weight | Product size |
|---------|----------|----------------|--------------|
| 4860PCS | 11790PCS | 1.30KG | 160/160/101 |

BC6403-B

Handle Compressor Nebulizer



Package content

| Box size (mm) | Carton size(mm) | PCS/CTN | KG/CTN |
|---------------|-----------------|---------|-----------|
| 175x132x270 | 680x180x560 | 10 | 14.5/15.5 |

| 20GP | 40HQ | Product weight | Product size |
|---------|----------|----------------|--------------|
| 4100PCS | 10000PCS | 1.29KG | 154/112/202 |

BC68001-C

Compressor Nebulizer



Package content

| Box size (mm) | Carton size(mm) | PCS/CTN | KG/CTN |
|---------------|-----------------|---------|--------|
| 175x175x170 | 545x190x520 | 9 | 13/14 |

| 20GP | 40HQ | Product weight | Product size |
|---------|----------|----------------|--------------|
| 4116PCS | 10160PCS | 1.32KG | 172/162/98 |

BC68001

Compressor Nebulizer



Package content

| Box size (mm) | Carton size(mm) | PCS/CTN | KG/CTN |
|---------------|-----------------|---------|--------|
| 170x115x235 | 595x175x490 | 10 | 14/15 |

| 20GP | 40HQ | Product weight | Product size |
|---------|----------|----------------|--------------|
| 5500PCS | 13300PCS | 1.25KG | 155/147/105 |

BC68001-E

Compressor Nebulizer



Package content

| Box size (mm) | Carton size(mm) | PCS/CTN | KG/CTN |
|---------------|-----------------|---------|--------|
| 170x115x235 | 595x175x490 | 10 | 14/15 |

| 20GP | 40HQ | Product weight | Product size |
|---------|----------|----------------|--------------|
| 5500PCS | 13300PCS | 1.09KG | 155/130/86 |

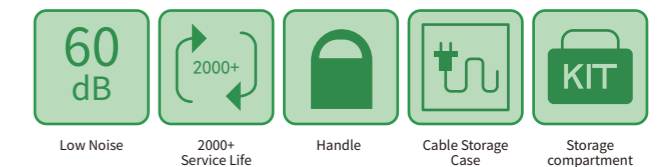

BC68001 is a high-end compressor nebulizer, with a low noise level and easy to use. The high performance compressor is suitable for continuous use and has a 2000+ hours non-stop service life.

TECHNICAL FEATURES

- Input: □220V/50HZ □120V/60HZ
- Power Consumption: 65W
- Medication Capacity: 6-8ml
- Particle Size: Respirable Fraction 0.5 to 5µm 0.5µm80%
- MMAD: 3-5µm
- Average Nebulization Rate: Above 0.3ml/min.
- Noise Level: Below 60 dBA
- Compressor Pressure Range: 30-45 Psi
- Operation Pressure Range: 12-14.5 Psi(0.85-1.1 bar)
- Liter Flow Range: 8~ 10 lpm

Accessories: Nebulizer cup, adult mask, child mask, inhalation mouth-piece, inhalation tube, air filter.



- 26 mm stamping a with rising temperature of about 180°C, which allows for 2000 hours of non-stop runtime without burning.
- 3 bearings in motor and metallic thermal protector (not disposable plastic type)
- fire retardant material



BC68002-C

Compartment Compressor Nebulizer



Package content

| Box Size (mm) | Carton Size(mm) | PCS/CTN | KG/CTN |
|---------------|-----------------|---------|-----------|
| 200x110x340 | 460x205x700 | 8 | 12.8/13.6 |

| 20GP | 40HQ | Product weight | Product size |
|---------|---------|----------------|--------------|
| 3800PCS | 9120PCS | 1.45KG | 289/180/107 |

BC68002

Durable Compressor Nebulizer



Package content

| Box size (mm) | Carton size(mm) | PCS/CTN | KG/CTN |
|---------------|-----------------|---------|--------|
| 170x118x275 | 610x175x570 | 10 | 16/17 |

| 20GP | 40HQ | Product weight | Product size |
|---------|----------|----------------|--------------|
| 4700PCS | 11200PCS | 1.51KG | 248/158/99 |

BC68002-D

Compartment Compressor Nebulizer

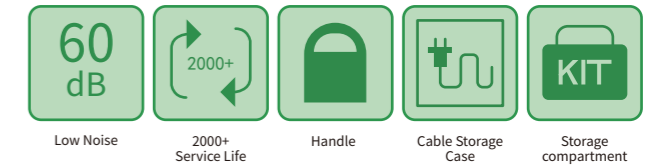

BC68002 is a high-end compressor nebulizer, with a low noise level and easy to use. The high performance compressor is suitable for continuous use and has a 2000+ hours non-stop service life.

TECHNICAL FEATURES

- Input: □220V/50HZ □120V/60HZ
- Power Consumption: 65W
- Medication Capacity: 6-8ml
- Particle Size: Respirable Fraction 0.5 to 5µm 0.5µm80%
- MMAD: 3-5 µm
- Average Nebulization Rate: Above 0.3ml/min.
- Noise Level: Below 60 dBA
- Compressor Pressure Range: 30-45 Psi
- Operation Pressure Range: 12-14.5 Psi(0.85-1.1 bar)
- Liter Flow Range: 8~ 10 lpm

Accessories: Nebulizer cup, adult mask, child mask, inhalation mouth-piece, inhalation tube, air filter.

Package content

| Box Size(mm) | Carton Size(mm) | PCS/CTN | KG/CTN |
|--------------|-----------------|---------|-----------|
| 185x118x300 | 610x190x620 | 10 | 16.1/17.1 |

| 20GP | 40HQ | Product weight | Product size |
|---------|---------|----------------|--------------|
| 3900PCS | 9500PCS | 1.47KG | 282/172/106 |

Bear Cartoon Compressor Nebulizer



BC68005-BR2

Pediatric Nebulizers

TECHNICAL FEATURES

- Input: □220V/50HZ □120V/60HZ
- Power Consumption: 65W
- Medication Capacity: 6ml
- Particle Size: Respirable Fraction 0.5 to 5µm 0.5µm80%
- MMAD: 3.0µm
- Average Nebulization Rate: Above 0.3ml/min.
- Noise Level: Below 60 dBA
- Compressor Pressure Range: 30-45 Psi
- Operation Pressure Range: 12-14.5 Psi(0.85-1.1 bar)
- Liter Flow Range: 8~ 10 lpm
- Operation Temperature Range: 10°C--40°C (50°F--104°F)
- Operation Humidity Range: 10 to 95% RH

Accessories: Nebulizer cup, adult mask, Pediatric mask mouth-piece, Tuble, air filter.

Package content

| Box Size (mm) | Carton Size(mm) | PCS/CTN | KG/CTN |
|---------------|-----------------|---------|--------|
| 205x135x250 | 560x215x525 | 8 | 12/13 |

| 20GP | 40HQ | Product weight | Product size |
|---------|---------|----------------|--------------|
| 3520PCS | 8480PCS | 1.42KG | 186/125/189 |



Cartoon design



Kids Use

60
dB

Low Noise



Optional Carry Bag

Cute designs for pediatric nebulizers. We has many innovation moulds ODM/OEM welcome
The bear design is compact and portable, very popular in the American and European markets.
One of Amazon' s hot sale items.
Carry bag is optional.

BC68005-BR1

Bear Compressor Nebulizer



BC68005-PG

Piggy Compressor Nebulizer



BC68005-TG

Tiger Compressor Nebulizer



BC68005-PD

Panda Compressor Nebulizer



TECHNICAL FEATURES

- Input: □220V/50HZ □120V/60HZ
- Power Consumption: 65W
- Medication Capacity: 6ml
- Particle Size: Respirable Fraction 0.5 to 5µm 0.5µm80%
- MMAD: 3.0µm
- Average Nebulization Rate : ≥0.3ml/min.
- Noise Level: Below 60 dBA
- Compressor Pressure Range: 30 ~ 45 Psi
- Operation Pressure Range: 12 ~ 14.5 Psi(0.85 ~ 1.1 bar)
- Liter Flow Range: 8 ~ 10 lpm

Accessories: Nebulizer cup, adult mask, child mask, inhalation mouth-piece, inhalation tube, air filter.

60
dB

Low Noise

2000+

Service Life

Handle

Cable Storage
Case

KIT

High Effective
Nebulizer Kit

Various design options, such as the ones seen above, and others available to request (animals like tigers, koalas, kittens).

Package content

| Box size (mm) | Carton size(mm) | PCS/CTN | KG/CTN |
|---------------|-----------------|---------|---------|
| 180x153x265 | 630x185x550 | 8 | 12.1/13 |

| 20GP | 40HQ | Product weight | Product size |
|---------|---------|----------------|--------------|
| 3520PCS | 8480PCS | 1.36KG | 166/140/213 |

BC68005-FS

Fish Compressor Nebulizer



A vivid and colourful fish moulding makes for an eye-catching nebulizer in any pharmacy. Durable and strong shell passed restric drop tests

TECHNICAL FEATURES

- Input: 220V/50HZ 120V/60HZ
- Power Consumption: 65W
- Medication Capacity: 6ml
- Particle Size: Respirable Fraction 0.5 to 5µm 0.5µm80%
- MMAD: 3.0µm
- Average Nebulization Rate: Above 0.3ml/min.
- Noise Level: Below 60 dBA
- Compressor Pressure Range: 30-45 Psi
- Operation Pressure Range: 12-14.5 Psi(0.85-1.1 bar)
- Liter Flow Range: 8- 10 lpm

Accessories: Nebulizer cup, adult mask, child mask, inhalation mouth-piece, inhalation tube, air filter.

Package content

| Box size (mm) | Carton size(mm) | PCS/CTN | KG/CTN |
|---------------|-----------------|---------|-----------|
| 275x160x180 | 660x280x380 | 8 | 12.1/12.8 |

| 20GP | 40HQ | Product weight | Product size |
|---------|---------|----------------|--------------|
| 3200PCS | 7760PCS | 1.33KG | 247/132/169 |

BC68005-DG

Puppy Compressor Nebulizer

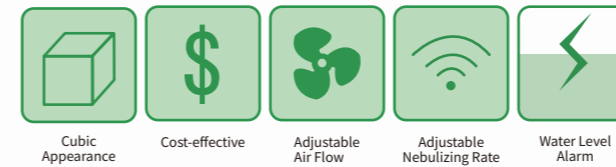

The puppy nebulizer is loved by children.

Give a hug to a puppy nebulizer when atomizing, and it can relieve children's anxiety, tension and irritability during nebulizing .

Package content

| Box size (mm) | Carton size(mm) | PCS/CTN | KG/CTN |
|---------------|-----------------|---------|-----------|
| 237x139x245 | 575x242x515 | 8 | 13.5/14.5 |

| 20GP | 40HQ |
|---------|---------|
| 3152PCS | 7600PCS |



BC68005-FT

Football Compressor Nebulizer

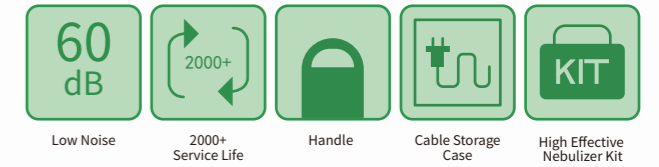

All designs can take off and become best-sellers.

New creative moulds can be made by our designers by your request.

Package content

| Box size (mm) | Carton size(mm) | PCS/CTN | KG/CTN |
|---------------|-----------------|---------|-----------|
| 200x200x200 | 615x205x630 | 9 | 13.5/14.4 |

| 20GP | 40HQ |
|---------|---------|
| 3195PCS | 7740PCS |

| Product weight | Product size |
|----------------|--------------|
| 1.33KG | 175/175/140 |

Nebulizer Kits

Highly effective Nebulizer Cup

Able to treat disease in different sections of the respiratory tracts.

TECHNICAL FEATURES

| | KIT-A | KIT-B | KIT-C/D |
|----------------------|---------|---------|---------|
| MMAD(um) | 3.0-5.0 | 2.5-4.0 | 2.0-2.5 |
| Max. Fill Volume(ml) | 8 | 6 | 6 |
| PCS per Kit | 5 | 6 | 6/3 |

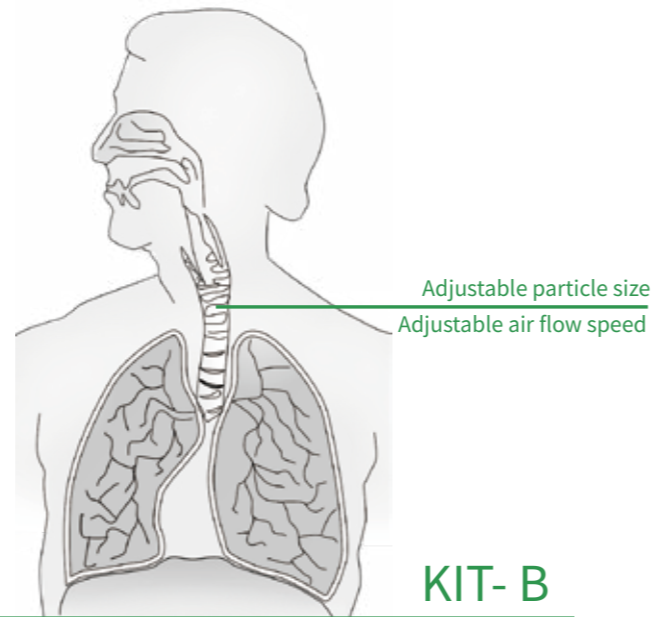

KIT-A



Adult Mask, Child Mask, Mouth Piece, Medicine Cup, Tube

| 20GP/40HQ | Carton size(mm) | PCS/CTN | KG/CTN |
|-------------|-----------------|---------|-----------|
| 35500/86000 | 580x380x360 | 100 | 10.0/11.0 |

KIT-C



Adult Mask, Child Mask, Mouth Piece, T-piece, Medicine Cup, Tube

| 20GP/40HQ | Carton size(mm) | PCS/CTN | KG/CTN |
|-------------|-----------------|---------|---------|
| 29000/69500 | 400x350x350 | 50 | 6.0/7.0 |

Compressor (Nebulizer / Suction)

Highly effective nebulizer pump with 3 bearings



Compressor Motor

SPECIFICATIONS

- Rated Current : $\leq 0.7A$ (when load)
- Rated Power : $\leq 80W$ (when load)
- NO-load Air Flow : $\geq 8 L/min$
- Load Air Flow : when 0.1 MPa (14.5 PSI) $\geq 5L/min$
- Max Pressure : 35 PSI
- Noise : $\leq 60 dB$



Package content

| Qty/Pallet | Pallet Size(mm) | N.W./G.W. |
|------------|-----------------|-----------|
| 704pcs | 1030X990X1030 | 630/650Kg |

| 20GP | 40HQ | Product weight |
|----------|----------|----------------|
| 18240PCS | 28160PCS | 0.88KG |

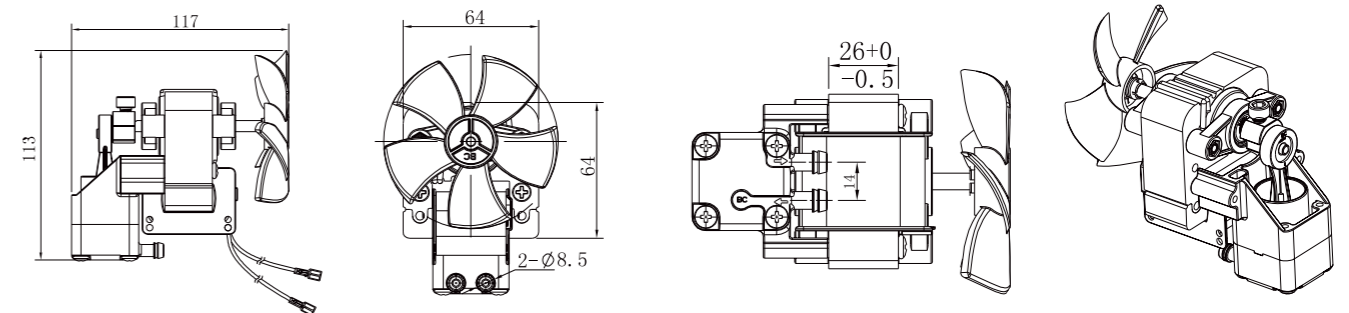

KIT-B



Adult Mask, Child Mask, Mouth Piece, L piece, Medicine Cup, Tube

| 20GP/40HQ | Carton size(mm) | PCS/CTN | KG/CTN |
|-------------|-----------------|---------|-----------|
| 26000/62200 | 600x400x380 | 100 | 10.0/11.7 |

KIT-D



T piece, Mouth Piece, Medicine Cup, Corrugated Tube, Tube

| 20GP/40HQ | Carton size(mm) | PCS/CTN | KG/CTN |
|--------------|-----------------|---------|-----------|
| 48500/118000 | 460x360x350 | 100 | 10.0/11.0 |

Accessories

Negative Pressure Catheter



Air Filter

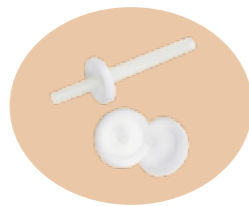

Sputum Suction Tube



Fuse Wire

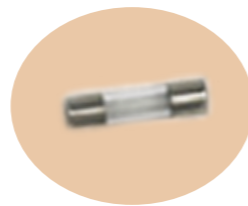

FO9001-A

Portable Suction Machine



FO9001-B

Portable Suction Machine



FO9001-C

Durable Suction Machine



SPECIFICATIONS

- Rated Voltage: AC220V ± 10% / 50Hz ± 2%
- Input Power: ≤ 90W
- Noise: 65 dB(A)
- Max Negative Pressure Value: ≥ 0.075MPa
- Pumping Rate: 15L/min
- Jug Volume: 1000 ml
- Continuous Working Time: within 30 min
- Rest Intervals: ≥ 30 min
- Portable design

Package content

| | Box Size (mm) | Carton Size (mm) | PCS/CTN | KG/CTN | 20GP | 40HQ |
|---|---------------|------------------|---------|-----------|---------|---------|
| A | 360x190x270 | 395x372x565 | 4 | 14.3/15.1 | 1360PCS | 3300PCS |
| B | 385x205x300 | 425x397x620 | 4 | 14.5/15.5 | 1080PCS | 2600PCS |
| C | 350x260x290 | 385x520x605 | 4 | 16.5/17.5 | 900PCS | 2156PCS |

FO9002-B/D

Electric Suction Apparatus



B



D

SPECIFICATIONS

- Voltage: AC220V ± 10%, 50Hz ± 2%
- Input power: 120VA
- Noise: ≤ 65dB
- Max negative pressure value: ≥ 0.09MPa
- Pumping rate: 30L/min
- Continuous Working Time: 0-30 min
- Bottle volume: 2500ml (2 bottles)

Package content

| | Box Size (mm) | KG/CTN |
|-----------|---------------|-----------|
| FO-9002-B | 475x415x925 | 16/18.5 |
| FO-9002-D | 465x415x645 | 11.5/13.8 |

KYZ2002-5L

5L Oxygen Concentrator



SPECIFICATIONS

- Max Flow : 5L/min
- Oxygen Density : 93%±3% [V/V]
- Running Noise : ≤ 53 dB [A]
- Power Consumption : ≤ 420 W
- Dimension : 36*34*59cm (wheels 5cm)
- N.W. : 15KG

Package content

| Carton size(mm) | Pcs/Ctn | Kgs/Ctn | 20GP/40HQ |
|-----------------|---------|-----------|-----------|
| 390x390x690 | 1 | 15.2/17.1 | 270/650 |

PH-Y05AW

5L Oxygen Generator







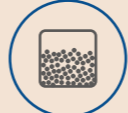

SPECIFICATIONS

- Max Flow : 5L/min
- Oxygen Density : 93%±3% [V/V]
- Running Noise : ≤ 53 dB [A]
- Power Consumption : ≤ 420 W
- Dimension : 30*40*54cm

Package content

| Carton size(mm) | Pcs/Ctn | Kgs/Ctn | 20GP/40HQ |
|-----------------|---------|---------|-----------|
| 470x410x690 | 1 | 17/18.5 | 210/510 |

| | | | | | | |
|---|---|---|---|---|---|---|
|  |  |  |  |  |  |  |
| Imported Molecular Sieve | Oil free Compressor | Smart alarm function | High purity oxygen ≅ 90% | Three level oxygen filter | Superior Oxygen atomizing technology | Optional Oxygen purity alarm |

KYZ2002-10L

10L Oxygen Concentrator



SPECIFICATIONS

- Max Flow : 10L/min
- Oxygen Density : 93%±3% [V/V]
- Running Noise : ≤ 60 dB [A]
- Power Consumption : ≤ 800 W
- Dimension : 39.6*35.9*61cm

Package content

| Box size (mm) | Pcs/Ctn | Kgs/Ctn | 20GP/40HQ |
|---------------|---------|---------|-----------|
| 460*480*700 | 1 | 25.3/30 | 180/438 |





HFA28-1

Upper Arm Automatic

3.5 inch screen

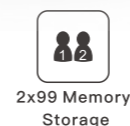

SPECIFICATIONS

- Display : LCD Digital Display
- Measurement Method : oscillometric method
- Measuring Range : static pressure 0 ~ 250 mmHg(0~33.33KPa)
- Pulse : 40~180 beats/min, ±5% of reading
- Static Pressure : ±3mmHg(±0.4KPa)
- Battery : 1.5V 4 "AA" batteries
- Product Dimension : 135.3mm * 115.24mm * 83mm
- Battery Life : Approx. 300 uses with 4 new alkaline batteries

Optional

- Backlight: 3 colors Backlight
- 1 color Backlight
- No Backlight

Package content

| Box size (mm) | Carton size(mm) | Pcs/Ctn | Kgs/Ctn |
|---------------|-----------------|---------|------------|
| 130x95x174 | 495x277x365 | 20 | 10.7/11.06 |

HFA28-2

Upper Arm Automatic

3.5 inch screen

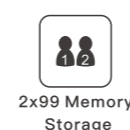

SPECIFICATIONS

- Display : LCD Digital Display
- Measurement Method : oscillometric method
- Measuring Range : static pressure 0 ~ 250 mmHg(0~33.33KPa)
- Pulse : 40~180 beats/min, ±5% of reading
- Static Pressure : ±3mmHg(±0.4KPa)
- Battery : 1.5V 4 "AA" batteries
- Product Dimension :135.3mm * 115.24mm * 83mm
- Battery Life : Approx. 300 uses with 4 new alkaline batteries

Optional

- Backlight: 3 colors Backlight
- 1 color Backlight
- No Backlight

Package content

| Box size (mm) | Carton size(mm) | Pcs/Ctn | Kgs/Ctn |
|---------------|-----------------|---------|------------|
| 130x95x174 | 495x277x36.5 | 20 | 10.7/11.06 |



Alternating pressure mattress
Anti-bedsore /Anti-decubitus

HF806T & HF6008

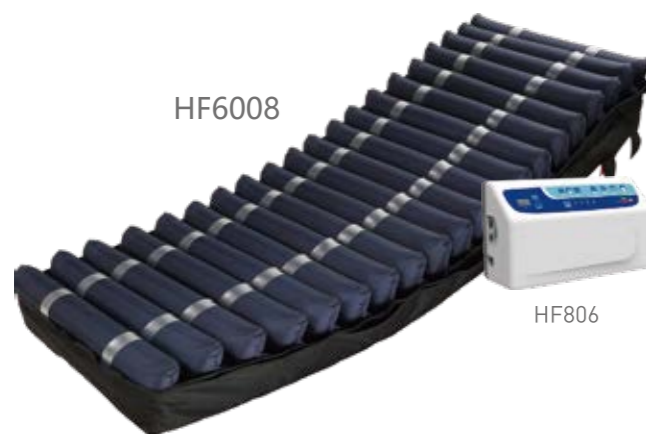

HF6008

HF806



Brief Tech Specs

- Product Code: HF6008+HF806
- Minimum Weight Limit: No Minimum
- Maximum Weight Limit: 200kg
- Mattress Size:80"(L)X36"(W)*8"(H)
- 200*90*20.5cm
- Material: Nylon TPU for air cells, Stretch PU cover, Bottom Tarpaulin/Nylon PU
- Pump Size:34.5(L)X19(W)X14.5(H)cm

Features and Benefits

- One in two cell-cycle design giving optimum therapy
- Taiwan Nylon TPU air cell construction, pillow function,
- Ventilation option
- Welded, seam sealed,easy to zip and waterproof stretch PU cover
- Easy turn CPR for rapid deflation
- Silent running pump at optimum support pressures
- Optional 10/15/20/25 mins cycle time
- Visual and audible alarms for patient safety
- External, easy replacement pump filters
- Static function with auto-return
- Automatically adjusts to the patients weight,
- seated and static functions included
- AB or ABC alternating option

Touch Panel



HF6001

Bubble air mattress



SPECIFICATIONS

HF62012 (Pump)

- Power Supply : 110V / 220V , 50~60Hz
- Air Output : 5~7 liter/min
- Pressure Range : 50mmHg~120mmHg
- Cycle Time : 12min
- Power Consumption : 7W
- Fuse : 1A
- Size : 23.5*12*9.5cm
- Weight : 1.4KG

HF6001 (Mattress)

- Material : Taiwan Nanya medical class PVC K80
- PVC thickness : 0.3 mm
- Color : beige , blue , green
- Style : 100 S/ 130 B bubble with end flaps
- Weight Capacity: 120~130KG
- Mattress Weight : 1.8~2.1KG
- Size : 200*90*7cm [Standard Size]
190*82*7cm [Economic Size]

HF6002

5" Tubular Air mattress



SPECIFICATIONS

HF601 (Pump)

- Power supply: 110V/220V/50-60Hz
- Air output: 6-8 liter/min
- Pressure range:50mmHg - 120 mmHg
- Cycle time: 12 min
- Power consumption: 7 W ;Fuse: 1A
- Size: 27.5 (L) X13.5 (W) X 9 (H) cm
- Weight: 1.6 kg

HF6002 (Mattress)

- Standard Size: 200*90*11.5cm
- Top cover: Nylon PU /strength
- Air cells:Nylon / PVC/TPU
- Mattress weight : 5.5-6.5kg
- Weight Capacity: 135-145kg

CPC, filter, fuse, hook, ventilation option included;
Aluminum pump system;
AB or ABC alternating option

HF6002 Series mattresses specifications

| Item | Size/Cells | Material | CPR | Cover | Flaps | Repair Kit | Spare cell | Ventilation | Pump |
|------------|---------------------------|-----------|-----|------------|-------|------------|------------|-------------|----------------|
| HF6005 | 200*90*11.5cm/18cells | Nylon TPU | ✓ | PU stretch | x | ✓ | ✓ | ✓ | Aluminum/HF608 |
| HF6002 | 200*90*11.5cm/18cells | Nylon PVC | ✓ | Nylon PVC | ✓ | ✓ | ✓ | Optional | Aluminum/HF601 |
| HF6002-17P | 190*85*11.5cm/17cells | PVC | ✓ | Nylon PVC | ✓ | ✓ | ✓ | ✓ | Normal |
| HF6002-22P | 186*80*7.5cm/22cells | PVC | x | x | x | ✓ | x | ✓ | Normal |
| HF6002-24 | 200*85*8.5cm/186*80*7.5cm | Nylon PVC | ✓ | Nylon PVC | ✓ | ✓ | ✓ | Optional | Normal |



FO3001

Air compression therapy (IPC)
4-6-8 chambers



Manual



Digital

SPECIFICATIONS

- Device size : 24cm*20cm*13cm
- Massage mode : Manual 1 mode , Digital 6 modes
- Pressure range : 30 ~ 250 mmHg
- Treatment time : 10 ~ 60 mins
- Power consumption : 65VA
- Each chamber can be partially skipped

Modes

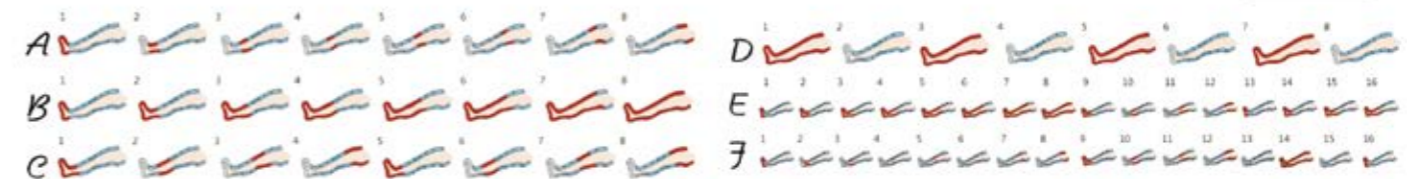

SLEEVES DISPLAY

| Sleeve | Description | Size |
|-------------|--------------|----------------------|
| Leg | Leg cuff M | 94*60cm |
| | Leg cuff L | 110*72cm OverLapping |
| | Leg cuff XXL | 125*76cm OverLapping |
| Arm | Arm cuff M | 88*50cm |
| | Arm cuff L | 90*60cm OverLapping |
| Waist | Waist cuff M | 120*37cm |
| | Waist cuff L | 133*37cm |
| Trousers | short pants | 80*76cm |
| | long pants | 142*85cm |
| Vest/ cloth | vest | 78*72cm |

FO3002

Portable recovery boots with battery
4-6-8 chambers



SPECIFICATIONS

- Device size : 25cm*12cm*9cm
- Massage mode : 5 modes
- Pressure range : 30 ~ 250 mmHg
- Treatment time : 10 ~ 60 mins
- Input : DC 15V /1500MA
- Each chamber can be partially skipped

Cuffs





KNOW ABOUT US



News Report

FOFO is a joint venture with Guangdong Kaiyang - the biggest wheelchair factory in China. We are growing fast and within 3 years became one of the top 3 manufacturers of alternating pressure mattresses in China and Taiwan. We are getting more and more international attention and have become one of the most trusted OEM/ODM factory worldwide.



FOFO

OUR GROUP

- 225 KW high frequency machine**
 Patented biggest high frequency machine can produce bubble mattresses in one-time moulding
- Double voltage auto-adjustment pump**
 Patented double voltage auto-adjustment pump for safe use in the Brasil market
- Own manufactured durable compressor**
 3 bearings in motor and metallic thermal protector (not disposable plastic type)
- 100% inflating QC before shipping**
 We keep 100% pumps and mattresses aging running for 6-12 hours before packing.
 Defect rate below 0.7% after use for 1 year

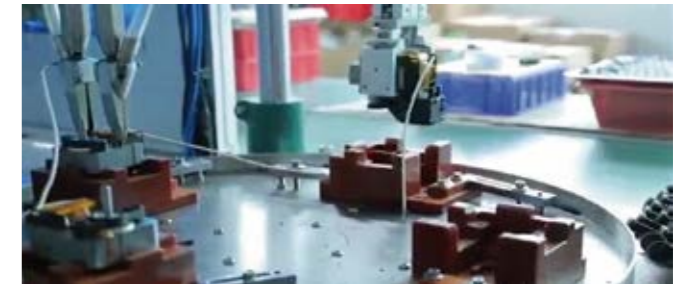

QUALITY CONTROL

Certificates and licences



1

FOFO MEDICAL Head office

Located in the beautiful island city of Xiamen, near Taiwan, and responsible for management, marketing, purchasing and R/D team

2

FOSHAN HONGFENG High frequency production

Manufacturing medical air mattresses, air compression therapy devices, BP monitors, water beds, air cushions

3

XIAMEN HEALTH REACH Electrical devices and parts manufacture

Manufacturing medical air pumps, air compression pumps, nebulizers, suction machines and motors

4

SHANGHAI PHOENIX MEDICAL Oxygen concentrators, nebulizers

Phoenix medical is located in the Phoenix Industrial Area in Danyang. It is the No.1 brand on the domestic market for bicycles. The main export markets are Europe and the USA



We manufacture and produce high quality, Anti-bedsore Medical Air Mattresses, Compressor Nebulizers, Suction Machines, DVT Air Compression Therapy, BP Monitors, Oxygen Concentrators, and other accessories such as Nebulizer Kits and Oxygen Masks.

We have branding orders for over 40 countries including Japan, USA, and major European countries, as well as other markets worldwide.

